

Application Guide

**For Grabo Commercial; Residential;
Homogeneous; Heterogeneous Vinyl
Floorings**

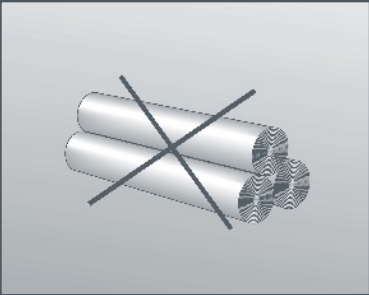

TABLE OF CONTENTS

Storage and Care Guide	3
Installation Technology	4
Sub-floor Requirements	4
Preparation of the Sub-floor	4
Installation	6
<i>Installation of Grabo Commercial Vinyl Floorings with Grabo Vaporex</i>	6
<i>Installation of Grabo Commercial Vinyl Floorings without Grabo Vaporex</i>	6
Gluing	7
Wet Gluing	7
Contact Gluing	7
Welding	9
<i>Heat Welding</i>	9
<i>Cold Welding</i>	11
Skirting	12
Cleaning and Maintenance Guide	13
General Notes	13
Preventive Measures	13
Basic Cleaning	14
Daily Cleaning	14
Cleaning and Maintenance Method Approved for Grabo Safety Floors	16
Recommended Cleansers	17
Cleaning Wet Areas	17
Stain Removal	18
Tools and Equipment	19



Storage and Care Guide



The Grabo commercial vinyl floorings are supplied in rolls. 21m rolls should be stored upright safely secured or on racks, other dimensions above 21m horizontally in their original packaging in dry, clean and well-ventilated premises. Outdoor storage undercover is not allowed. Ensure the storing temperature between +10°C and +35°C. Avoid storage in premises with high moisture content and/or condensation. The relative moisture content in the storing premises should be within 40–75%.

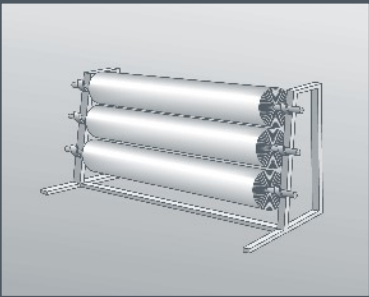

The GraboWeld welding rod used for heat welding should be stored under the same conditions as the flooring sheets, in its original packaging that should not be opened before use.

If stored in heated premises, the PVC products should be protected from heat. The distance between the heat source and the stored products should be at least 1 meter.

The products should be protected from direct sunlight and artificial light with high UV levels.

The product should not be exposed to strain, pressure or other load during storing in order to prevent permanent deformation and cracking.

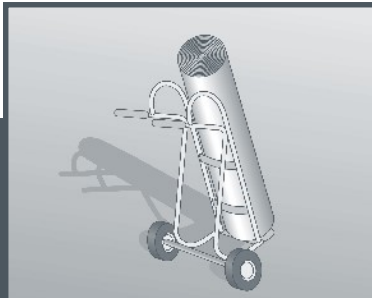

Appropriate storing conditions and adequate handling of the commercial PVC floorings will help to retain their properties till the end of their life-time. In case of extended storing (for more than one year) an adhesion test is recommended prior to the installation of the product. Only the rolls from a similar batch and having the same lot number should be used for the same premises. Prior to installation of the flooring visually inspect the sub-floor for general appearance, color and surface condition. The manufacturer does not assume responsibility for any additional labor or cost expenses resulting from evident surface defects.



Installation of Grabo Vinyl Floorings

Sub-floor Requirements

The contractor performing the installation of the Grabo vinyl floorings must ensure the proper quality of the sub-floor.

The sub-floor must be clean, smooth, permanently dry, free of cracks and any contaminants that might affect adhesion (e.g. paint, oil, grease, plaster or adhesive), sufficiently hard and resistant to pressure and tension strain.

In case of concrete and sand/cement screed sub-floors, their moisture content should not exceed 2.0%.

If the sub-floor moisture content exceeds 2.0%, but does not reach 5%, the damp proof membrane Grabo Vaporex should be installed underneath the PVC flooring system. If the sub-floor moisture content exceeds 5%, do not start installation before it goes below 5% or install a damp proof membrane underneath the commercial PVC flooring system.

It is recommended to check the condition of the sub-floor by performing the required tests and measurements prior to installation of the flooring. Check the surface level (using a ruler or a measuring wedge), as well as the absence of cracks, the moisture content (using a hydrometer) and the surface hardness (scratch test). Document the obtained test results.

The sub-floor temperature directly before installation of the flooring should be between +15°C and +30°C.

Preparation of the Sub-floor (New or Existing Bases)

Prepare the new concrete base by stone or power grinding and vacuum cleaning.

In case of new gypsum based screed sub-floors remove the loose upper gypsum layer by grinding.

In case of existing carpet and rubber flooring, upon removing the old carpet or rubber sheets clean the surface from traces of paint and adhesive, then patch or fill the cracks and hollows, if any, before installing the new floor covering.

If the new flooring is to be installed on top of a PVC base or ceramic tiles, thoroughly clean the surface by abrasion and vacuuming, fill the joints with a suitable repair composition and apply an approved primer compound to the entire surface.

If the new flooring is to be installed over existing wooden or laminated floors, confirm that the boards are securely fixed and properly dried. Firmly nail any loose elements to the joists and replace any boards with moisture content higher than required. The surface then should be sanded and cleaned from

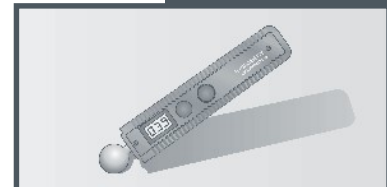

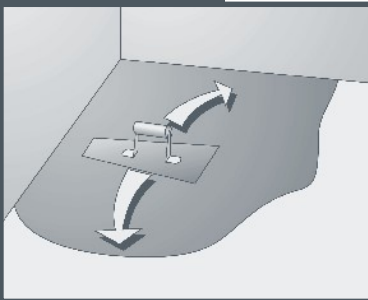
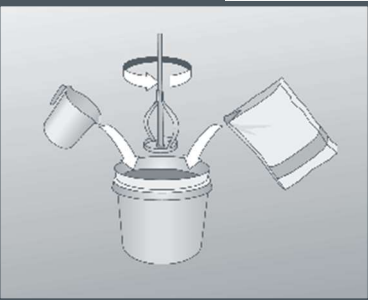
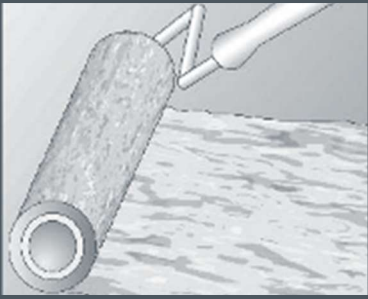

dust and treated with an appropriate primer compound. To the preparation and floor laying instructions we recommend to use UZIN, Ceresit products which can as well be replaced by products of any other brand with similar technical properties.

For the pre-treatment of absorbent surfaces use dispersion primer e.g., UZIN PE 360; Ceresit R 777; apply the primer with nylon fiber roller and leave it to dry.

Use primer UZIN PE 280; Ceresit R 766 to hard, dense, non-absorbent surfaces. The primer will trap the remaining dust, close the pores in the concrete and increases fluidity and workability of self-leveling compounds.

After the primer has been completely absorbed, the surface needs to be leveled using a suitable smoothing compound (e.g. self-leveling compound UZIN; Ceresit). When choosing the self-leveling compound, consider the expected traffic load and the time allotted for the installation of the flooring. Thoroughly mix the powder with water according to manufacturer's instructions and then spread the smooth paste on the surface with a flat trowel. Occasional air bubbles should be removed with the help of a spiked roller. After the surface has completely dried up, it should be smooth-finished and cleaned from dust.

The Grabo vinyl floorings are suitable for underfloor heating. If underfloor heating is used on the site, the heating system must be switched on at least four weeks before installation of the new flooring. Switchoff the underfloor heating 24 hours before commencement of work and keep it turned off till installation of the PVC flooring has been completed. Wait 48 hours after the flooring has been installed and then switch on the heating again. Raise the temperature steadily till it reaches its usual value over approximately 5 days. While using underfloor heating, the temperature of the sub-floor must not exceed 28°C.

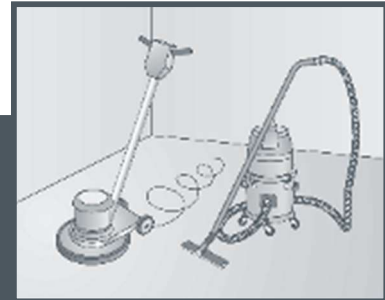
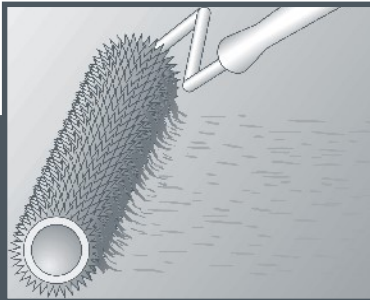



Installation of Grabo Vinyl Floorings

While the measured sub-floor moisture content stays within 2.0–5CM%, the use of damp proof membrane Grabo Vaporex is mandatory. If the measured sub-floor moisture content is below 2.0%, the use of damp proof membrane Grabo Vaporex with Grabo vinyl floorings can be waived.

The use of Grabo Vaporex underlay is advisable in the case of existing concrete bases, vinyl floorings and metal bases and mandatory for asphalt sub-floors.

Installation of Grabo Vinyl Floorings with Grabo Vaporex underlay:

The underlay must be unrolled and tempered on the site at a temperature of at least 18°C for one day prior to installation.

The Grabo Vaporex underlay should be placed on the even, dry and clean sub-floor prepared according to instructions, with the pattern side facing down. Fold up the edges near the walls for at least 10 centimeters and trim accordingly. Adjust the underlay sheets edge-to-edge and then fasten the edges on the top (of the plain side) with a 5 cm wide vinyl adhesive tape. The underlay should lie flat on the surface. While Grabo Vaporex can be laid both lengthwise and crosswise, the crosswise installation is advised. Make sure the underlay joints do not fall together with the seams between the flooring sheets installed on top of the underlay. The Grabo commercial vinyl floorings should be glued to the underlay using a dispersion contact adhesive (e.g. UZIN KE2000Si; K 188E;).

Spread the adhesive evenly on the underlay surface using an A4 notched trowel, maintaining the spread rate of approximately 250 g/m². Leave the adhesive to evaporate completely till it changes from opaque to transparent yellow. After approximately 60–90 minutes test it with your finger, and if not anymore tacky, the adhesive bed is ready to accept the flooring sheets.

Further steps (e.g. welding) are the same as described below for the installation of Grabo vinyl floorings without Grabo Vaporex underlay.

Installation of Grabo Commercial Vinyl Floorings without Grabo Vaporex:

The flooring must be unrolled and tempered on the site at a temperature of at least 18°C for one day prior to installation. Use the flooring rolls from a similar batch and having the same lot number for installation in the same premises. It is advisable to open the rolls in the ascending order of their lot numbers. When laying the flooring with a wood imitating pattern the subsequent strips should point in the same direction, otherwise lay every next strip with the pattern pointing in the reverse direction compared to the previous row. The arrow on the back side of the roll shows the correct laying direction. After tempering the unrolled floor covering trim the sheets to size on both ends with a 5 cm allowance, then place them on the sub-floor and align precisely edge-to-edge. The rolls should be installed lengthwise, following the direction of the sunlight as it falls on the floor. Fold back the flooring strips to half of their length before applying the adhesive.

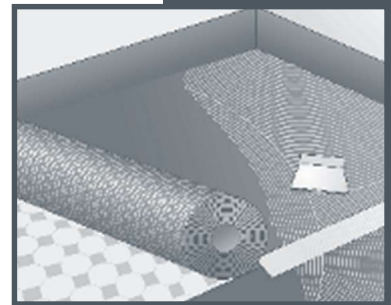
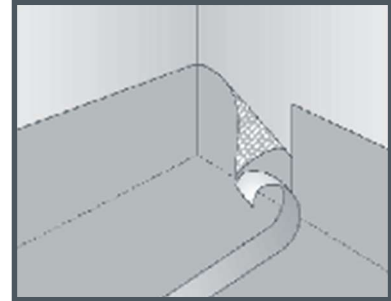

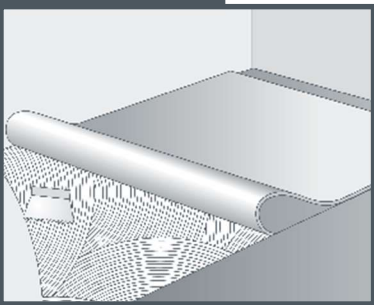
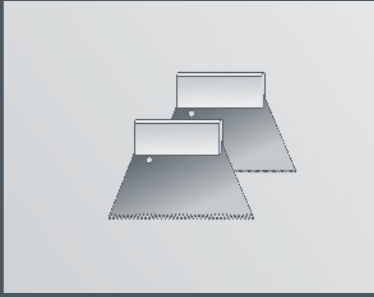

Gluing

We recommend using solvent-free low emission dispersion adhesives to Grabo vinyl floorings. Two adhering methods can be advised – based on wet set adhesives and contact adhesives.

Wet Gluing:

In case of hygroscopic sub-floors (concrete, sand/cement screed) the use of dispersion or emulsion acrylic adhesive is recommended.

The adhesive should be stored in frost-free environment and tempered on the site at a temperature of at least 18°C for one day prior to installation. Stir up the adhesive thoroughly before use.

Recommended adhesives: Mapei - Ultrabond ECO V4 Evolution; UZIN KE2000s; Strongbond 2000.

Spread the adhesive on the sub-floor using an A3 or a B1 notched trowel, maintaining the spread rate of approximately 300–400 g/m². Be sure to check the condition of the notched strips regularly and re-cut as necessary.

Always follow the adhesive manufacturer's instructions regarding the optimal quantity, the open time and the drying time of the adhesive. A shorter open time will lead to the appearance of air bubbles, whereas a longer open time will reduce the bonding capacity.

Contact Gluing:

The use of contact adhesives can be recommended for both hygroscopic sub-floors (concrete, sand/cement screed) and impervious (PVC) substrates. Only contact adhesives should be used for impervious sub-floors. Recommended adhesive: UZIN KE 2000Si; Ceresit K 188E which is a solvent-free dispersion adhesive suitable for contact application.

Apply the adhesive to the sub-floor and spread evenly using an A2 or A4 trowel and maintaining the spread rate of approximately 200–250 g/m².

Leave the adhesive to evaporate completely till it changes color from opaque to transparent yellow. After approximately 60–90 minutes test it with your finger, and if the adhesive is not tacky anymore, start to position the folded back flooring sheet onto the adhesive bed.

Grabo vinyl floorings are compatible with underfloor heating. The wet set and contact adhesives mentioned above are also suitable for such installations.



To ensure good bonding, thoroughly smooth the flooring sheet, working from the center outwards, with the help of a manual cork rubber, confirming no air bubbles are trapped underneath. Finally roll the installed flooring using a 50–60 kg roller. Repeat the sequence to install the other half of the flooring sheet.

In order to make site formed coved skirting, draw a line on the wall to mark the height the coving will reach and fit the capping strip to the wall using contact adhesive. Attach the cove former in a similar way: using a brush, apply contact adhesive to the back of the cove former and to the wall up to the capping strip and leave both to dry. When completely dry, firmly push the vinyl with the cove former into place and tuck the top edge into the capping strip.

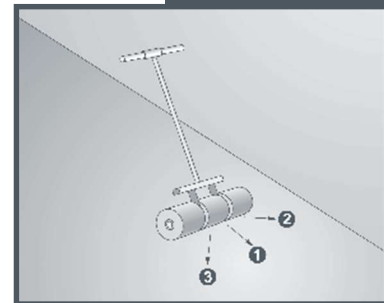
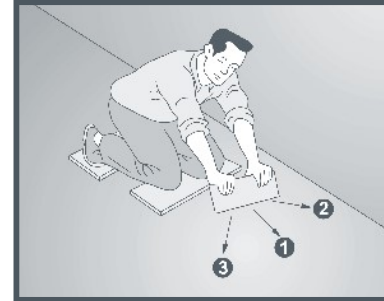



Welding

Welding can be performed after no less than 24–48 hours upon installation, depending on the kind of the applied adhesive and the adhesive manufacturer's instructions.

Heat Welding

Application of heat welding is mandatory for wet areas and premises with underfloor heating.

When the flooring is ready, the joints should be grooved to appropriate depth and width either manually, or with an automatic groover.

The recommended groove width is 2–3 mm. The joints should be thoroughly cleaned from any debris. Use \varnothing 4 mm GraboWeld welding rod for heat welding to all vinyl floors.

Set the working temperature of the heat welding gun to approximately 300–400 C°. The welding can be carried out with the help of an automatic appliance or with a hand-operated welding set. Before starting the procedure, trial welding is recommended in order to set the optimal welding temperature and speed.

After the welding seam has cooled down, remove the excessive welding rod in two steps.

First cut off the top half of the welding rod using a quarter moon knife. After the remaining weld has cooled to the room temperature, perform the final trim.

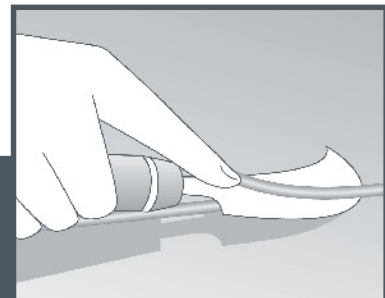
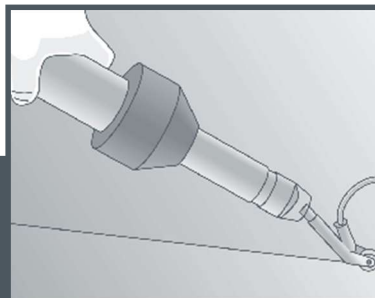
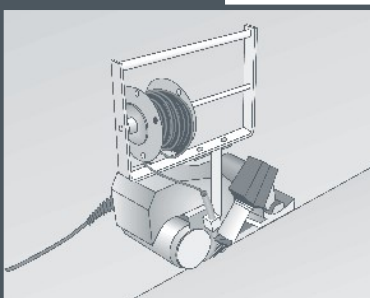
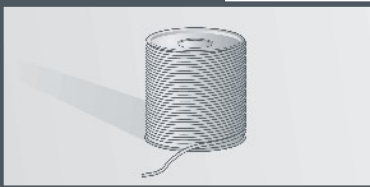
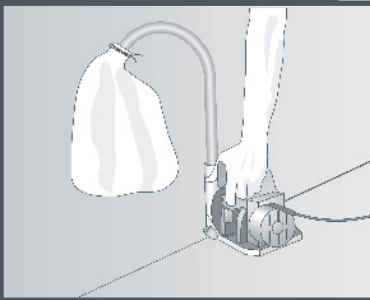



Heat welding in the corners:

From the perspective of the flooring external and internal corners are distinguished. Fitting of welds in internal corners can be performed in two ways: either by precision cutting and subsequent silicon filling of the seam, or by „half-rod” welding. In the latter case, the welding rod cut-offs from the first trim can be used to fill in the vertical seams by pressing them into the vertical grooves with the rounded side down and then applying heat coagulation to the joints. The excess welding rod should be trimmed off. It is recommended to pre-heat the coves before welding the joints.

Precision cutting is important for external corners as well. Corner welding should be performed with a welding rod.

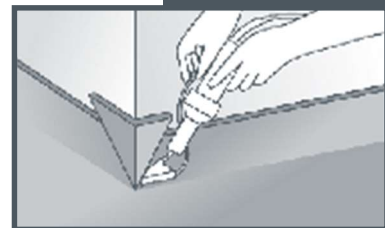
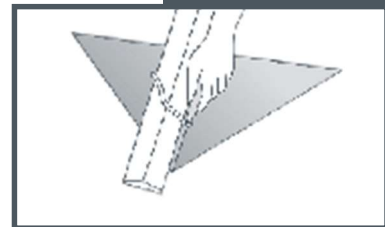
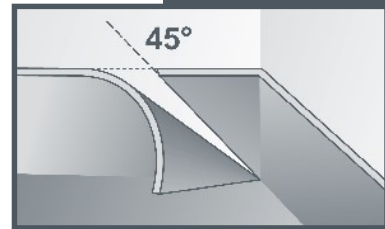



Cold Welding

Cold welding is another common technique used for the installation of commercial PVC floorings.

This method ensures quick seam closing and is especially suitable for chip floors and all-over surfaces, as it produces an integral seamless covering for large areas.

The cold welding technique consists of four steps:

1. Place the PVC flooring strips so as they overlap for approximately 3–5 cm. Cut the sheets lengthwise along a metal rule and remove the cut-off waste from both the top and the bottom layer.
2. Center the masking paper tape over the closely cut joints of the PVC strips and press it on tightly with a roller to stop the cold welding paste from sneaking while being filled into the joint.
3. Cut through the masking tape simply and firmly along the seam with a circular cutter (or a trapezoid blade).
4. Thoroughly shake up the tube with the cold welding paste. Press the nozzle of the cold welding paste tube deeply into the joint with one hand and pull the tube along the joint. Use your other hand to dose the cold welding paste so that an approximately 5 mm wide line appears on the surface of the masking tape. Allow bonding for ten minutes and then remove the masking tape. The result is an almost invisible waterproof seam.

Use Werner Mueller cold welding paste Type A for sealing new PVC floorings and Type C to repair the existing surfaces.

Successful cold welding requires the use of the tools and equipment shown in the picture. For details of cold welding technique see your language version of the manufacturer's site: www.mueller-pvc-naht.de

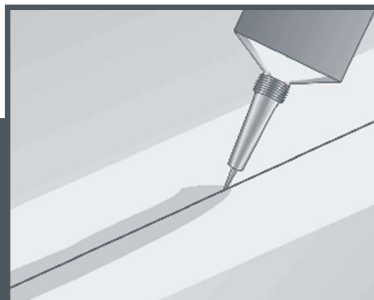
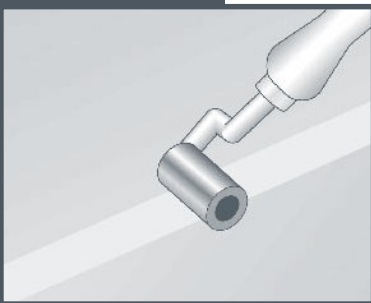
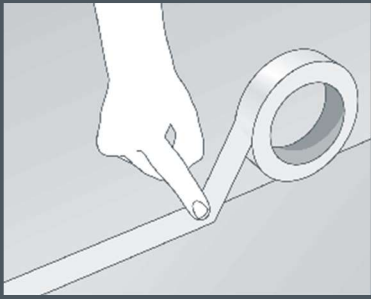



Skirting

Flash coving is an extension of the sheet flooring up the wall to form a wall base. This can be accomplished by either one-piece flash coving, border flash coving, or two-piece flash coving. All seams in the flash cove area should be treated the same as seams throughout the rest of the installation. Grabo flooring accessories are manufactured under strict quality control from a blend of quality raw materials. To achieve best finish to your flooring we recommend to use our following profiles
 GraboProfil Set-In Skirting 100mm
 GraboProfil Cove Form 25x25mm
 GraboProfil Set-In Skirting 100mm
 GraboProfil Cap 3mm

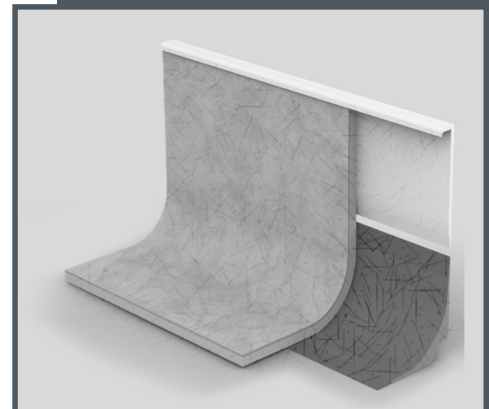



Cleaning and Maintenance Guide for Grabo Vinyl Floorings

General Notes

Regular cleaning and maintenance are crucial for the durability and attractive appearance of your flooring. The floor maintenance schedule is primarily determined by the intensity of the traffic load.

Routine (daily) cleaning and periodical general maintenance are indispensable for preservation of the long-term appearance and performance of Grabo floor coverings.

Apart from the approved maintenance products listed in this guide, other cleansers with similar parameters (chemical formulation and pH-value) are also compatible for use with Grabo commercial vinyl floorings.

Do not use cleaning products that could damage the surface, e.g. abrasive cleaners or organic solvent-based detergents.

As a general rule, always follow the detergent manufacturers' instructions and contact them for additional details when required.

Cleaning and maintenance procedures for Grabo safety floorings are described in a separate user guide.

Preventive Measures

Most of the dirt, grit and moisture that will need to be cleaned from the floor surface arrive from the street. Most of this soiling can be kept outside by using efficient dirt barrier systems of appropriate size. The maintenance regime depends to a great extent on how efficiently the dirt is stopped at the front door.

Another point to consider is the use of high-quality heavy-duty plastic pads ("footies") to be attached to furniture legs to protect the floor from scratching.

The newly installed floor covering needs a basic cleaning that should be later repeated between certain periods of use.

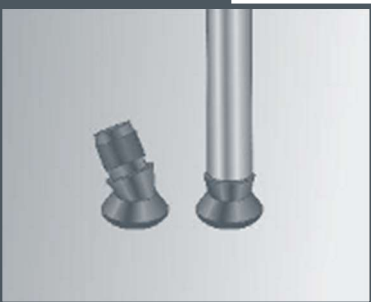
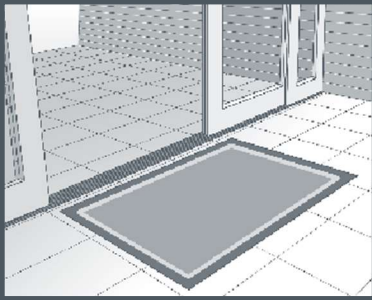



Basic Cleaning

- Remove loose debris, dirt and sand by sweeping and/or vacuum cleaning the surface.
- Remove the stubborn stains and built-up dirt.

Cleaning Chemicals and Equipment

- Highly alkaline basic cleanser (pH13-14)
- Rotary single disc scrubber machine with a red cleaning pad
- Wet vacuum equipment
- Coarse sweep broom, floor squeegee

The use of power cleanser for basic cleaning helps to remove the built-in dirt quickly and radically. It is a water-soluble ten side based detergent (also available with disinfectant component).

Procedure

Apply the diluted cleanser to the surface of 5–10 m² and leave it for about 10–15 minutes to react with the soiling. Then machine scrub the floor, pick up the slurry, rinse thoroughly with clean water, pick up the water with a wet vacuum cleaner and leave to dry.

The frequency of basic cleaning depends on the intensity of the floor covering use.

Generally it is normal to perform a basic cleaning once in 1–3 months, depending on the intensity of use.

Daily Cleaning

- Remove loose debris, dirt and sand by sweeping and/or vacuum cleaning the surface.
- Manually damp-mop the floor or perform wet machine cleaning.

Cleaning Chemicals and Equipment

- pH-neutral or slightly alkaline cleanser (pH 7-10)
- Alcohol based cleanser
- Mop with a mop handle
- Coarse sweep broom, floor squeegee
- Brush scrubber dryer machine

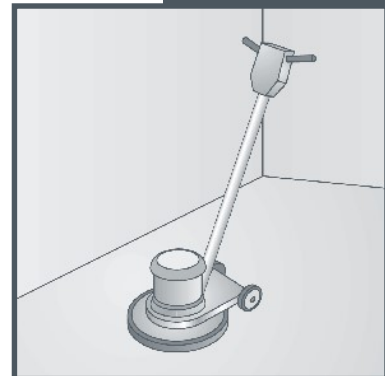
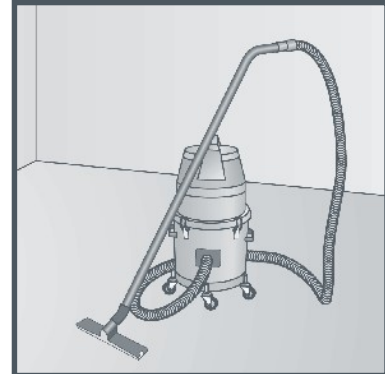



Manual damp-mopping

The usual daily cleaning set includes a mop with a mop handle and a suitable cleanser. Use anionic detergent or non-anionic, tenside based alcohol cleanser to preserve the original shine of the floor covering surface and achieve quick drying leaving no streaks or dull film.

Use the two-bucket method for cleaning vinyl floors.

Apply a pH-10 detergent and a scrubbing brush to heavily soiled surfaces. Then rinse with clean water and wipe dry.

Machine wet cleaning

Use a brush scrubber dryer machine for best results. Use a pH-10 detergent for cleaning heavily soiled surfaces. Then rinse with clean water and wipe dry.

Healthcare applications

Certain types of Grabo commercial vinyl floorings are perfectly suitable for installation in healthcare facilities. The same cleaning procedures as described above work for these applications as well, with disinfectant added to the detergent solution. Contact the manufacturer for advice on choosing an adequate cleaning product.

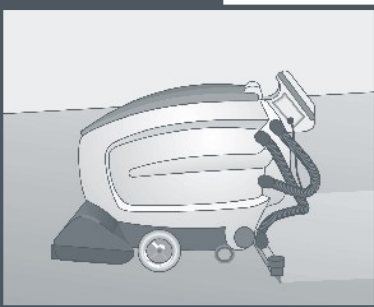



Cleaning and Maintenance Method Approved for Grabo Safety Floors

Grabo safety floorings offer ultimate security and enhanced slip resistance due to their surface design and chemical properties. Because of extreme surface roughness, these floorings are not suitable for manual cleaning and require machine cleaning only. The Grabo Safety products are not compatible with anionic surfactants, as their surface smoothing effect reduces the performance and functionality of the product.

Initial Construction Clean and Basic Cleaning Procedure

Clean the flooring from all loose debris, dirt and dust. Vacuum-clean the surface thoroughly and then machine scrub with a scrubber dryer fitted with a suitable cleaning pad and using an alkaline detergent. Pick up the slurry with a wet vacuum cleaner, rinse with clean water no less than twice, pick up the rinsing water with a wet vacuum cleaner and leave the surface to dry.

If the premises are too small for machine cleaning, use a ridged scrubbing brush to scrub the floor.

Daily Cleaning

Clean the flooring from all loose debris, dirt and dust. Vacuum-clean the surface thoroughly and then machine scrub with a scrubber dryer fitted with a suitable cleaning pad and using a pH-neutral or slightly alkaline detergent. Pick up the slurry with a wet vacuum cleaner, rinse with clean water twice, pick up the rinsing water with a wet vacuum cleaner and leave the surface to dry.

If the premises are too small for machine cleaning, use a ridged scrubbing brush to scrub the floor.

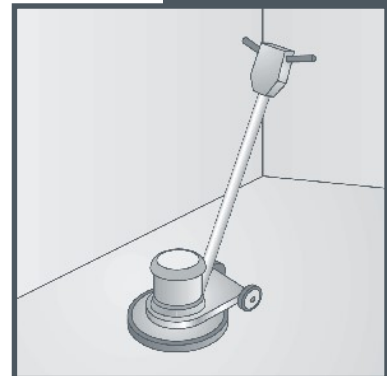
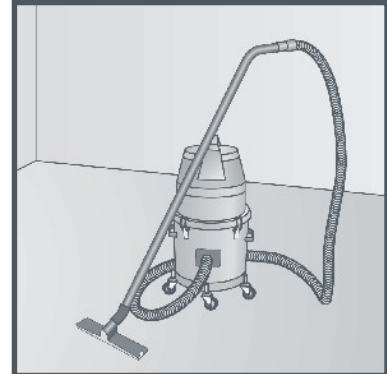



Approved Cleansers

Manufacturer / Trade mark	Werner&Mertz GmbH	Dr. Schutz
Basic cleaning	Quick-Stripper pH 13-14 concentration: 5-10 %	Clean and Strip pH 14 concentration: 10%
Daily manual cleaning	SR 13 pH 9 concentration: 0,5 %	Active Cleaner R280 pH 8,5 concentration: 0,3-0,5%
Daily machine cleaning	Innomat pH 10 concentration: 0,3-0,5%	Floor Cleaner R 1000 pH 9,5 concentration: 0,3-0,5%
Stains removal	Elatex	

Cleaning Wet Areas

Acidic detergent (e.g. pH 3–5) can be useful for occasional application on areas where the surface is subject to lime scale deposit. Wet vacuum the soiled water, then rinse the surface with clean water and wet vacuum again. Always keep a mop set handy in the premises exposed to water, so as to pick up all spills or leaks immediately in case of necessity. This will help to prevent lime scale deposit on the vinyl flooring.



Stain Removal

Stains should be removed immediately, as certain stains can impregnate the PVC upper layer and cause irreparable discoloration. Such stains can be caused by asphalt, crayons, printer ink, ball-pen filler paste, shoe polish, paint used in some plastic doormats, rubber foot of household appliances, the wheels of a forklift, or even a color plastic bag. The PVC floor can be stained by asphalt, tar and similar soiling of the shoe soles, especially in warm weather. A non-staining doormat (without rubber or latex lining) placed at the entrance can help to stop most of the dirt and soiling brought along on the shoe soles.

Stains	Stain removal tips
Chocolate, grease, fruit juice, ice-cream, coffee, lemonade, tea, wine, eggs or beer stains	wipe off with a solution of pH-neutral detergent and warm water.
Asphalt, rubber, oil, shoe polish, soot, crayon, lipstick, felt-tip pen stains	wipe off with cleaning naphtha or methyl alcohol using a white or a nylon cloth.
Candle wax and chewing gum	freeze the chewing gum with nitrogen spray or apply a special orange oil chewing gum remover and then scrape the material off.
Blood stains	wash off with cold water, add a few drops of ammonia when required.
Rust and lime	use a slightly acidic cleanser (pH 3-4).
Adhesives	use adhesive remover or naphtha. Then rinse with clean water and leave to dry thoroughly.

UPON REMOVAL OF ANY STAIN ALWAYS WIPE THE FLOOR WITH CLEAN WATER AND A MOP OR A NAPKIN.

Tools and Equipment

For Grabo flooring products use tools and equipment provided by the Wolff Company.

For details and a product catalogue visit <https://int.wolff-tools.com/>

Sub-floor Preparation

- Rotary single disc grinding machine SAMBA with all accessories.
- Industrial vacuum cleaner STRAVAC MI55
- Tools for stripping the existing floor covering (DURO-STRIPPER; PRIMO-STRIPPER)
- Equipment for structural moisture analysis (Hydrometer V1-D4 Pro)
- Equipment for measuring temperature and relative humidity (Digital Thermo-Hygrometer LVT15 Pro)
- Sub-floor hardness tester
- Hand mixer MIXER POWER X 1600 with suitable mixing blades
- Flat trowel



**Rotary single disc grinder SMABA
with accessories**

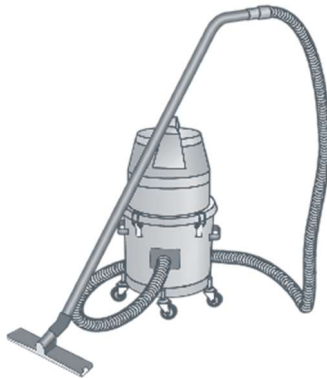

**Industrial vacuum cleaner
STRAVAC MI55**



**Tools for stripping the existing floor
covering (Duro-Stripper, Primo-Stripper)**



Sub-floor hardness tester



Equipment for structural moisture analysis (V1-D4 Pro)



Equipment for measuring temperature and relative humidity (Digital Thermo-Hygrometer LVT15 Pro)



Mixer X 1600 with suitable mixing blades



Flat trowel



Installation of the floor covering

- Adhesive trowels
- Groover tool
- Joint strippers, joint trowels (for small and medium-size surfaces)
- Heat welding gun (Phoenix 1600; Leister Triac S, Leister HOT-JET S)
- Automatic welding machine (Wolff Weldmaster; Leister Unifloor – for larger surfaces)
- Standard welding nozzles (speed weld nozzle, universal nozzle)
- Weld trimmer
- Quarter moon knife
- Trimmer knife (for corners and edges)
- Cold welding set – Werner Mueller cold welding paste tube with nozzle, flipper knife, trapezoid blade, curled end quarter moon knife, masking paper tape
- GraboWeld welding rod for heat welding, round section, \varnothing 4 mm
- Safety cutter (Flipper 3000)
- Tape measure, rule, steel ruler
- Cork rubber pad
- Hand roller 50 kg

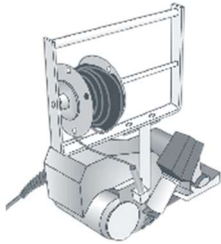

Automatic welding machine

(Weldmaster – for larger surfaces)



Heat welding gun

(Leister Triac S., Leister HOT-JET S)



Wolff Master Groover

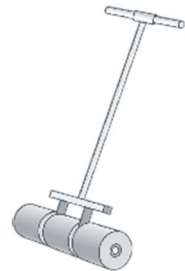

Hand roller 50 kg



Tape measure, rule,
steel ruler



Trapezoid blade

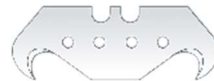

Hooked blade



Safety cutter (Flipper 3000)



Adhesive trowels



A2 serrated spatula



B1 serrated spatula

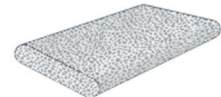

Cork rubber pad



Joint trowels



Quarter moon knife



Standard welding nozzles
(speed weld nozzle, universal nozzle)

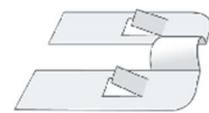

Weld trimmer



Joint strippers

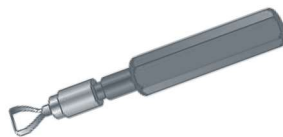

Trimmer knife
(for corners and edges)



GraboWeld welding rod
for heat welding

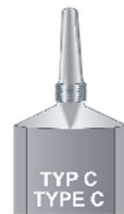

Cold welding paste



Graboplast Floor Covering Manufacturers Ltd.
H-9023 Győr, Fehérvári út 16/B Tel.: +36 96 506-365

